

HYVA 4-169-1530-C Dump Truck Cylinder

Product Code :

Reference No :

- A : 169
- B : 60
- C : 201
- D : 65
- E : 190
- H : 100
- J : 96
- L : 1530
- L* : 1550
- R : 53
- S : 42

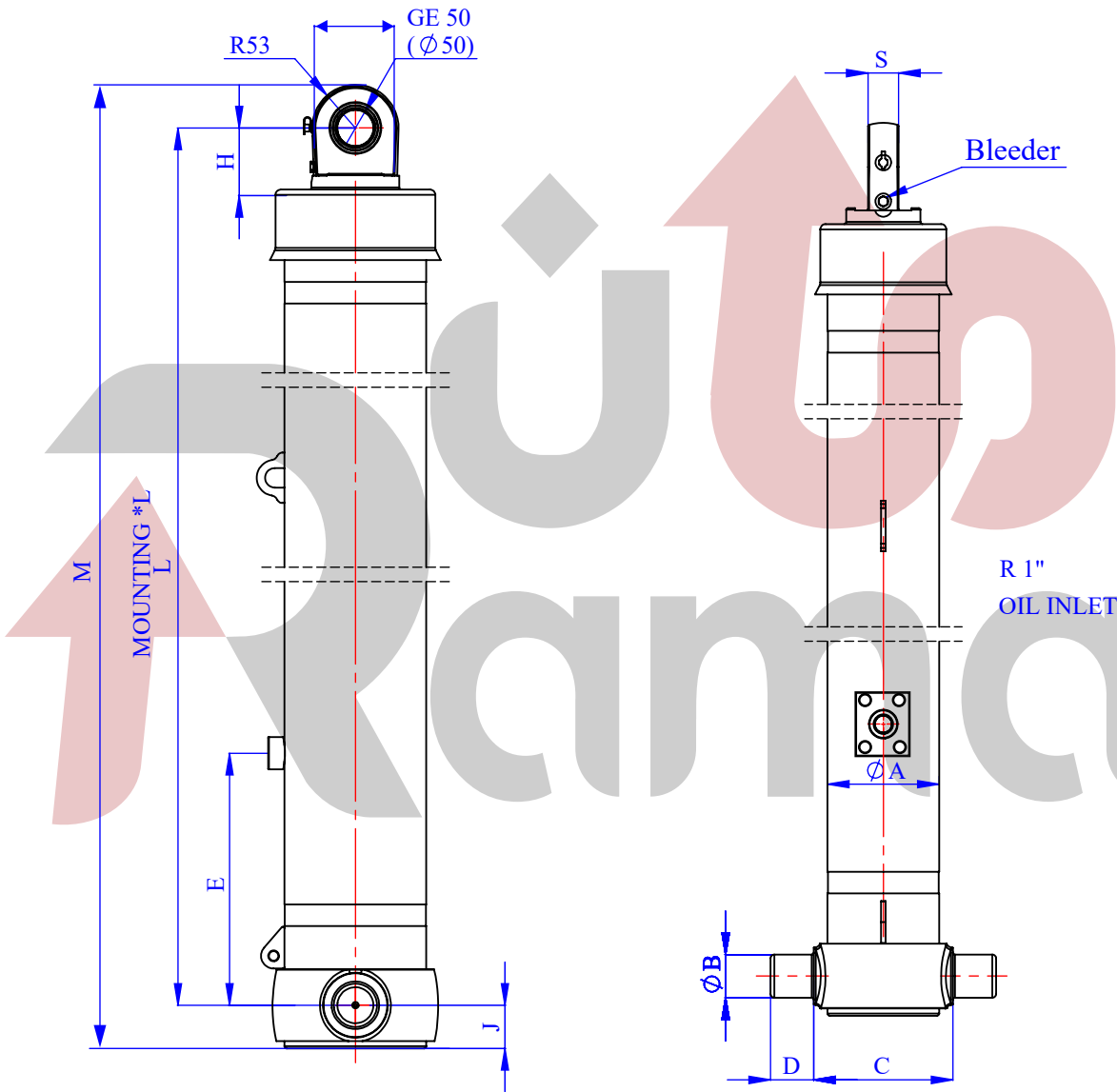

EFFECTIVE DIAMETER (mm)						149	129	110	91		total
STROKE (mm)						1245	1245	1245	1245		4980
THRUST AT 170 BAR (TONS)						33	28.5	21.2	12.6		

All sizes were given as mm

SPECIFICATIONS

- Number of Stages : 4 Stages
- Stroke : 4980 mm
- *Inc 20 mm pull out : Tolerance +30 ; -5
- Working Pressure : 170 Bar
- Max. Working Pressure : 190 Bar
- Working Temperature : -40 °C / +80 °C
- Total Volume : 63 L
- Weight Cylinder : 180 Kg
- Tipping Weight : 37.5 Ton
- All Cylinder Materials are St 52 Cold Down Tubes
- Standard Cylinder is Painted with RAL 9005

FORMULATION

- St : (Stroke)
- Bl : (Body Length)
- Ro : (Rear Overhang)
- Pl : (Pivot Length)
- C : (Bracket Length)

$$\alpha^\circ = \frac{St \times 60}{Pl}$$

