

Afhymat 4-170-1459-C Dump Trailer Cylinder

Product Code :

Reference No :

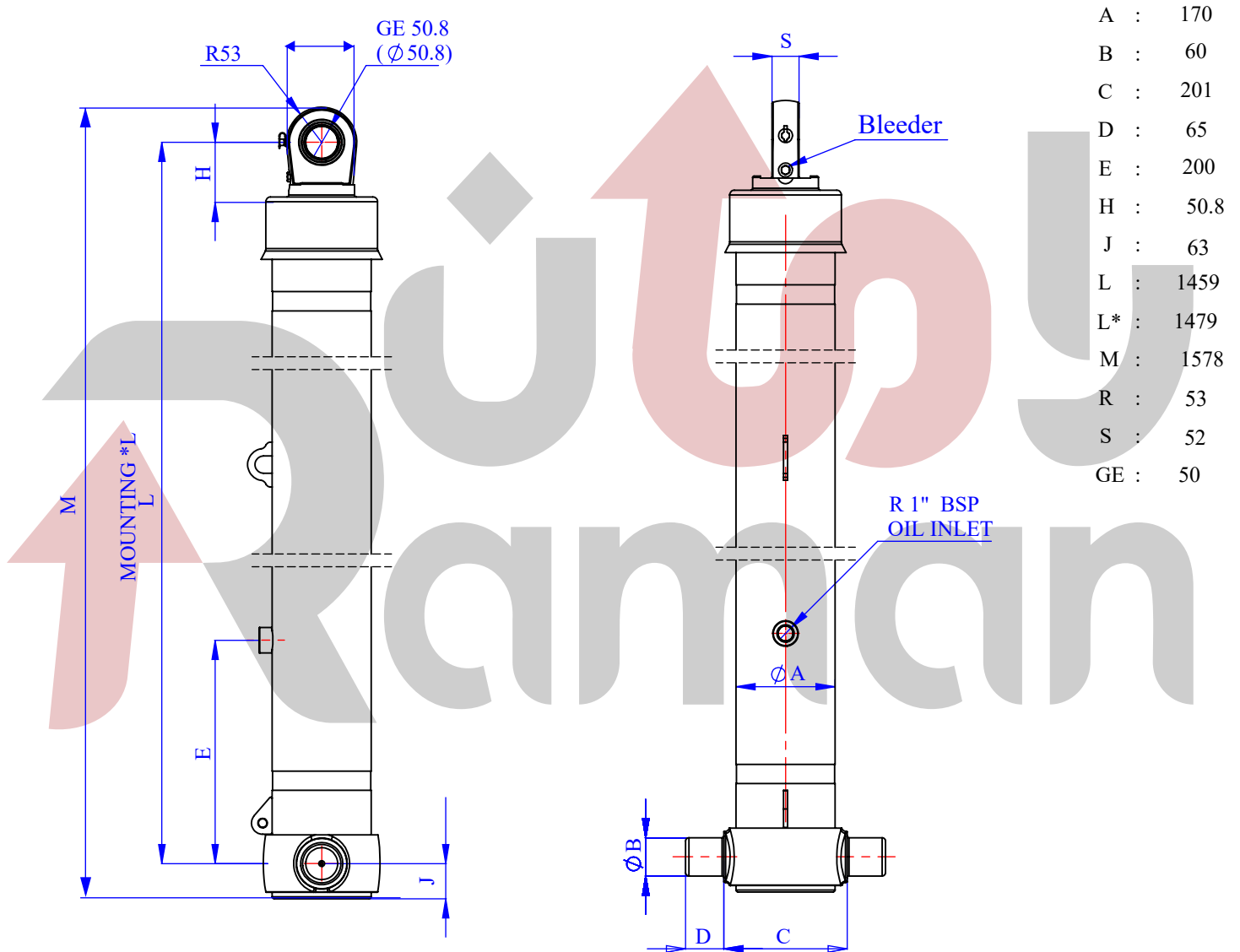

A :	170
B :	60
C :	201
D :	65
E :	200
H :	50.8
J :	63
L :	1459
L* :	1479
M :	1578
R :	53
S :	52
GE :	50

EFFECTIVE DIAMETER (mm)					150	130	111	92			TOTAL
STROKE (mm)					1135	1135	1135	1135			4540
THRUST AT 190 BAR (TONS)					33.6	25.2	18.4	12.6			

All sizes were given as mm

**SPECIFICATIONS**

- Number of Stages : Stages
- Stroke : 4540 mm
- \*Inc 20 mm pull out : Tolerance +30 ; -5
- Working Pressure : 190 Bar
- Max. Working Pressure : 250 Bar
- Working Temperature : -30 °C / +70 °C
- Total Volume : 60 L
- Weight Cylinder : 175 Kg
- Tipping Weight : 44.1 Ton
- All Cylinder Materials are St 52 Cold Down Tubes
- Standard Cylinder is Painted with RAL 5005

**FORMULATION**

- St : (Stroke)
- Bl : (Body Length)
- Ro : (Rear Overhang)
- Pl : (Pivot Length)
- C : (Bracket Length)

$$\alpha^\circ = \frac{St \times 60}{Pl}$$

