

Hidrosir 4-165-1230-C Dump Truck Cylinder

Product Code :

Reference No :

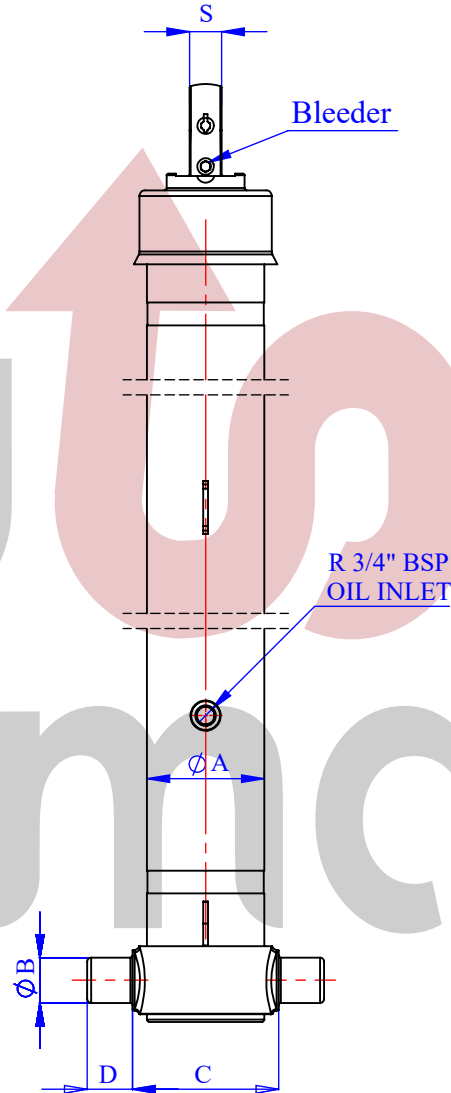
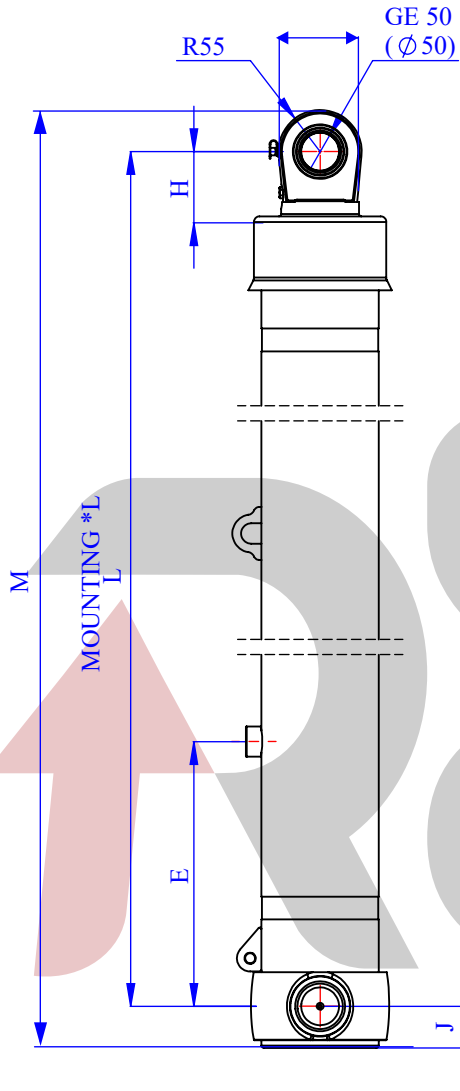

A :	165
B :	68
C :	210
D :	60
E :	175
H :	94
J :	55
L :	1230
*L :	1260
M :	1340
S :	40

EFFECTIVE DIAMETER (mm)						135	115	95	75		TOTAL
STROKE (mm)						950	950	950	950		3800
THRUST AT 170 BAR (TONS)						24.3	17.7	12	7.5		

All sizes were given as mm

**SPECIFICATIONS**

- Number of Stages : 4 Stages
- Stroke : 3400 mm
- \*Inc 30 mm pull out : Tolerance +20 ; 0
- Working Pressure : 170 Bar
- Max. Working Pressure : 190 Bar
- Working Temperature : -23 °C / +80 °C
- Total Volume : 48 L
- Weight Cylinder : 158 Kg
- Tipping Weight : 27.2 Ton
- All Cylinder Materials are St 52 Cold Down Tubes
- Standard Cylinder is Painted with RAL 1036

**FORMULATION**

- St : (Stroke)
- Bl : (Body Length)
- Ro : (Rear Overhang)
- Pl : (Pivot Length)
- C : (Bracket Length)

$$\alpha^\circ = \frac{St \times 60}{Pl}$$

