

Hidromas 5-197-1847-C Dump Trailer Cylinder

Product Code :

Reference No :

A :	197
B :	60
C :	240
D :	60
E :	350
H :	94
J :	60
L :	1847
*L :	1877
M :	1967
S :	42

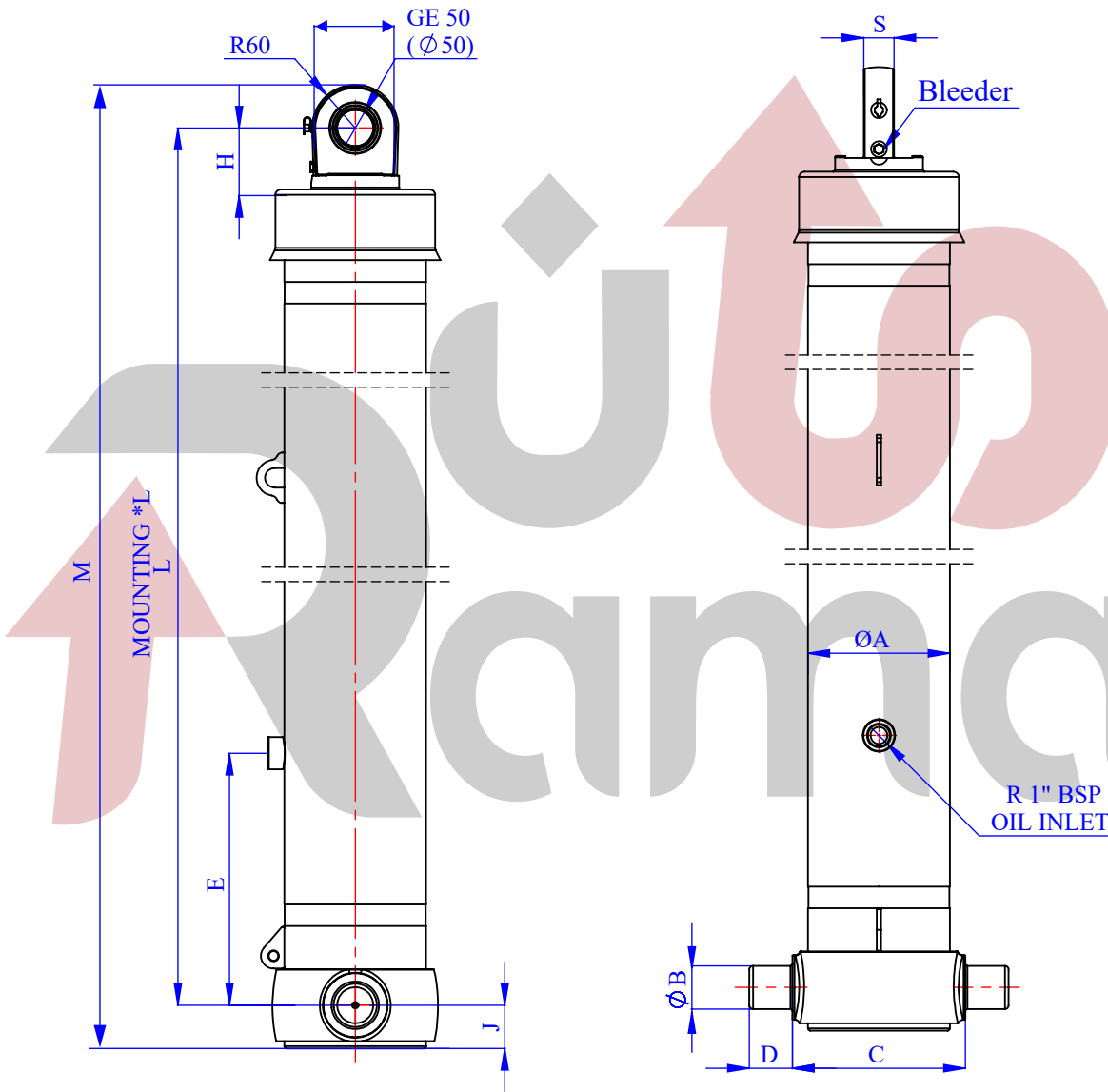

EFFECTIVE DIAMETER (mm)				175	155	135	116	98			TOTAL
STROKE (mm)				1510	1510	1510	1510	1510			7550
THRUST AT 170 BAR (TONS)				40.9	32.1	24.3	18	12.8			

All sizes were given as mm

SPECIFICATIONS

- Number of Stages : 5 Stages
- Stroke : 7550 mm
- *Inc 30 mm pull out : Tolerance +20 ; 0
- Working Pressure : 170 Bar
- Max. Working Pressure : 190 Bar
- Working Temperature : -23 °C / +80 °C
- Total Volume : 130 L
- Weight Cylinder : 306 Kg
- Tipping Weight : 45.7 Ton
- All Cylinder Materials are St 52 Cold Down Tubes
- Standard Cylinder is Painted with RAL 1036

FORMULATION

- St : (Stroke)
- Bl : (Body Length)
- Ro : (Rear Overhang)
- Pl : (Pivot Length)
- C : (Bracket Length)

$$\alpha^\circ = \frac{St \times 60}{Pl}$$

