

HYPO 43 ISO GMP Bi 30S 4H

HYPO 43 Liter ISO Gear Pump Bi 30 Series 4 Holes

Product Code /
 Ref. No : 0000

: 840356840665
 248300353866

Bi

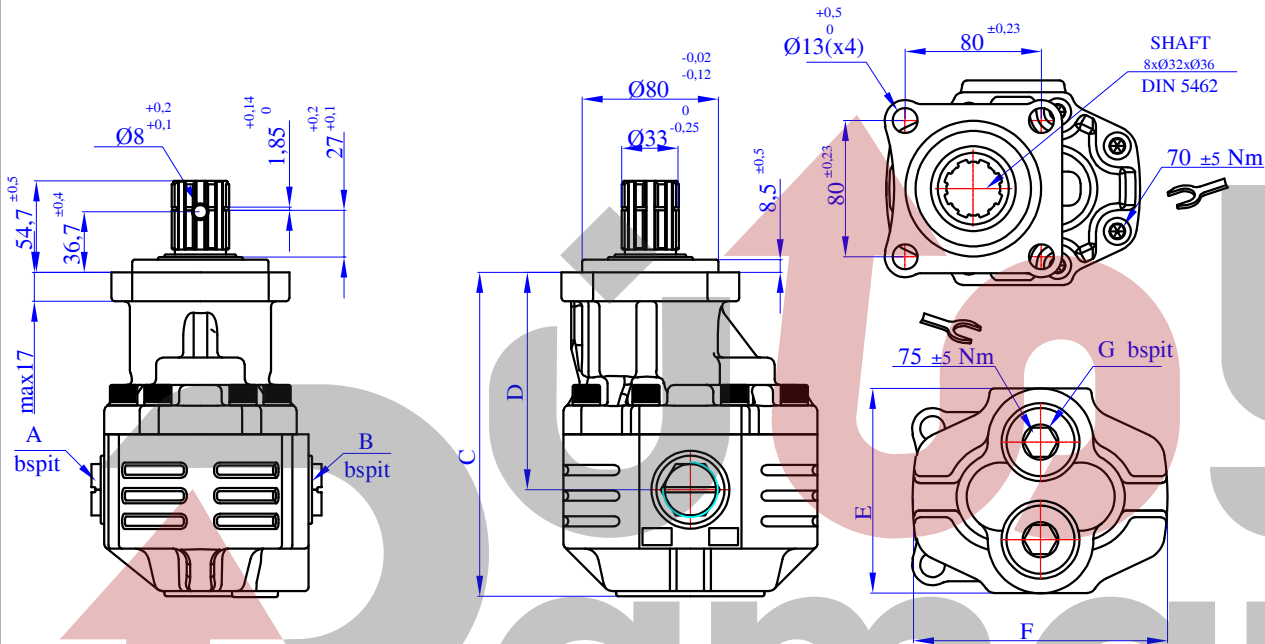

A : G 1"
 B : G 1"
 C : 199
 D : 142
 E : 130
 F : 155
 G : G 1"
 H :
 I :
 J :

TECHNICAL DATA

Specifications

Displacement	43	cm ³ /rev
Max. Peak Pressure (P3)	290	bar
Max. Intermittent Pressure (P2) (for tipping applications)	260	bar
Max. Continuous Pressure (P1)	200	bar
Max. Speed at Intermittent Press.	2800	rev/min
Min. Speed at Intermittent Press.	300	rev/min
Max. Speed at Continuous Press.	2200	rev/min
Oil Temperature Range	-40+80	C
Inlet Pressure Range (suction side)	0.7-3	bar
Recommended Oil Viscosity Range	12-100	mm ² /s (cSt)
Max. Starting Viscosity	750	mm ² /s (cSt)
Filtration:		
-Working Pressure < 200 bar	25	micrometer
-Working Pressure > 200 bar	10	micrometer
Connection:		
Min. Suction Hose Bore Diameter	-	inch
Weight	12	kg
Rust prevent oil applied shaft area	protect 12 months	

Pressure Definition

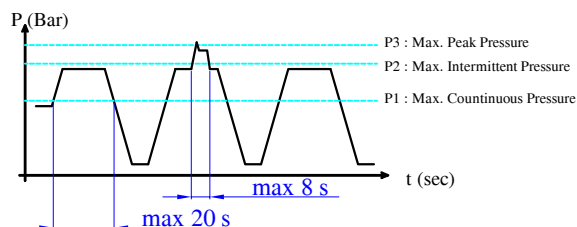

Hydraulic Pump Symbol

