

Hidromas 4-155-1312-C Dump Truck Cylinder

Product Code :

Reference No :

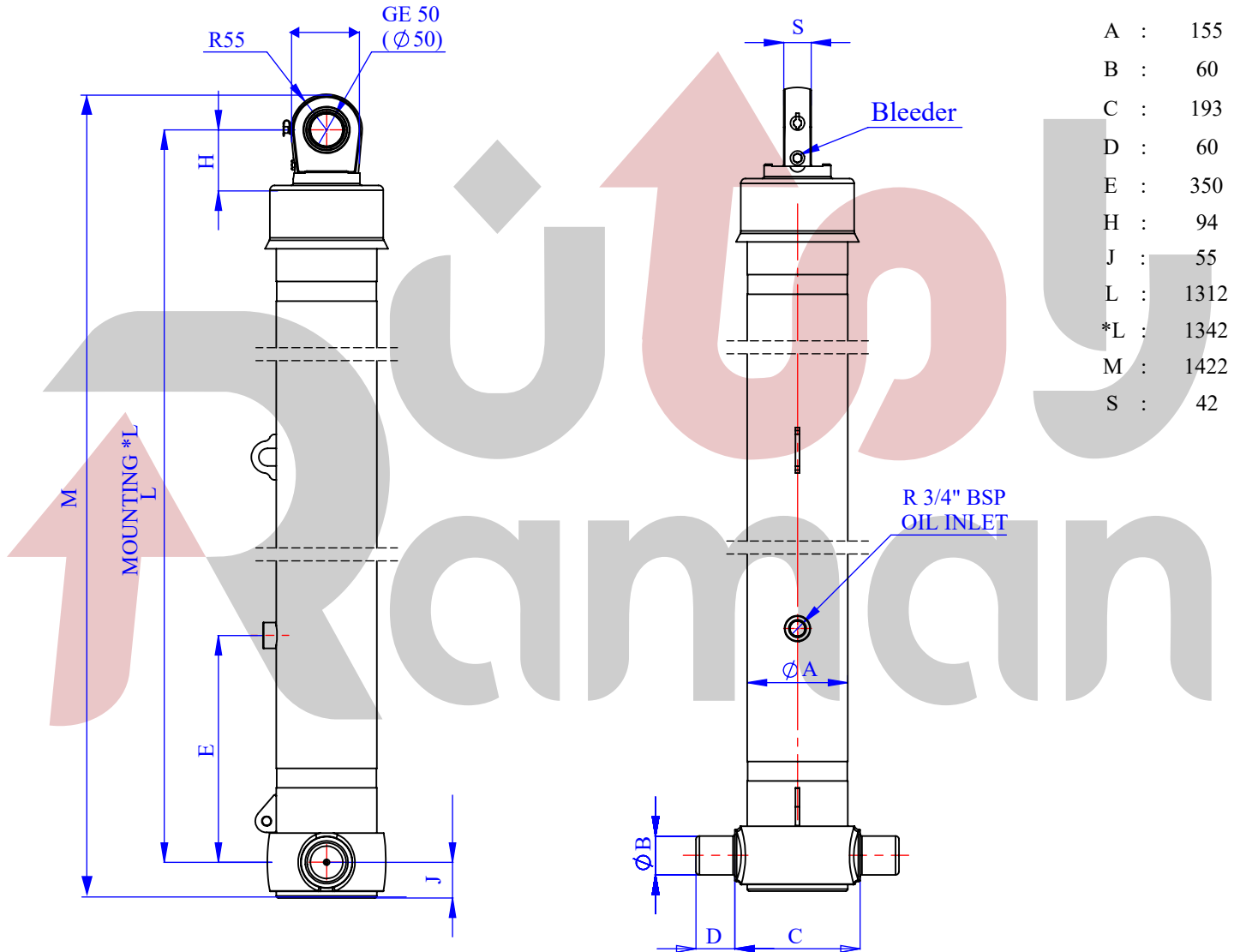

A :	155
B :	60
C :	193
D :	60
E :	350
H :	94
J :	55
L :	1312
*L :	1342
M :	1422
S :	42

EFFECTIVE DIAMETER (mm)						135	116	98	80		TOTAL
STROKE (mm)						1025	1025	1025	1025		4100
THRUST AT 170 BAR (TONS)						24.3	18	12.8	8.5		

All sizes were given as mm

SPECIFICATIONS

- Number of Stages : 4 Stages
- Stroke : 4100 mm
- *Inc 30 mm pull out : Tolerance +20 ; 0
- Working Pressure : 170 Bar
- Max. Working Pressure : 190 Bar
- Working Temperature : -23 °C / +80 °C
- Total Volume : 45 L
- Weight Cylinder : 136 Kg
- Tipping Weight : 27.2 Ton
- All Cylinder Materials are St 52 Cold Down Tubes
- Standard Cylinder is Painted with RAL 1036

FORMULATION

- St : (Stroke)
- Bl : (Body Length)
- Ro : (Rear Overhang)
- Pl : (Pivot Length)
- C : (Bracket Length)

$$\alpha^\circ = \frac{St \times 60}{Pl}$$

